



TNC225R

THERMAL NIGHT VISION COMPACT 225 LRF

THERMAL NIGHT VISION MULTI-SPECTRUM SCOPE

CONTENTS

THERMAL NIGHT VISION COMPACT 225 LRF

Thermal Night Vision Multi-Spectrum Scope

THERMAL NIGHT VISION COMPACT 225 LRF

Thermal Night Vision Multi-Spectrum Scope

SAFETY INSTRUCTIONS

- ⦿ DO NOT look directly into the INFRARED (IR) Illuminator to avoid damages to your eyes.
 - ⦿ Switch off the IR Illuminator when not in use. Continuous use of IR light will generate excessive heat. Avoid pointing it towards flammable objects.
 - ⦿ Do not point the device at strong light sources such as the sun, open flames, etc, as this may cause damage to thermal sensor.
 - ⦿ Device operating temperature -4F-122F (-20~50°C).
 - ⦿ Please contact us if there is any malfunctions, Please do not attempt to disassemble the scope.
-

DESCRIPTION

TNC225R is a Thermal and Night Vision multispectral digital scope that can be used 24/7 in all-weather conditions. Digital Night Vision combined with a thermal sensor enables faster target detection with the benefit of a high quality digital image for identification.

PACKAGE CONTENT

- TNC225R Scope
- Eye Cup
- Mount Accessories
- USB Cable
- User Manual

SPECIFICATIONS

| Model | | TNC225R | | |
|---|---|-------------------------------------|--------------------------------|--------------------------|
| Physical Specifications | | Display Specifications | | |
| Net Weight | 645g / 22.8oz | Type | Micro-OLED | |
| Dimensions | 170 x 83 x 79mm / 6.7 x 3.3 x 3.1inches | Display Resolution | 1024x768pixels | |
| Storage | Internal Storage, 32GB | Frame Rate | 50FPS | |
| WIFI/APP | Yes | Power Specifications | | |
| Bluetooth | Yes | Battery Type | 18650 Battery (flat top) | |
| Laser Rangefinder Maximum Detection Range | 5 - 1000m / 5-1100yds | Operating Time | 5h | |
| Operating Temperature | -20 ~ 50°C / -4F ~ 122F | External Power Supply | 5V - Type C USB | |
| Water Proof | IP67 | | | |
| Recoil Proof | 800Gs | | | |
| Digital Day/ Night Vision | | Thermal | | |
| Sensor Specifications | Resolution | 1920x1080pixels | Resolution | 256x192pixels |
| | Frame Rate | 60FPS | Sensor | Uncooled Infrared Sensor |
| | Video Record Resolution | 1024x768pixels | Frame Rate | 50FPS |
| Optical Specifications | Focal Length of Objective Lens | 52mm | Pixel Size | 12x12um |
| | Base Magnification | 5x | NETD | ≤25mk @25°C |
| | Digital Zoom | 5x, 7.5x, 10x, 12x, 15x, 17.5x, 20x | Focal Length of Objective Lens | 25mm |
| | Eye Relief | 45mm / 1.8inches | Base Magnification | 3x |
| | Diopter Adjustment | ±5D | Digital Zoom | 3X, 6X, 9X, 12X |
| | IR Wavelength | 850/940nm | | |
| IR Illuminator | Class 3R Eye Safe | | | |

■ FEATURES

- Three imaging modes: Day/Night mode, Thermal mode, and PIP with Day/Night & Thermal combined mode.
- Video recording resolution: 1024*768.
- Ultra HD image quality, Micro-OLED 1024*768 display.
- Full screen recording including on screen display, reticle, LRF etc.
- One shot zero.
- Picture-in-Picture.
- Reticle Zeroing in Picture-In-Picture mode.
- Digital image & thermal image alignment.
- Removable IR illuminator.
- 3-Axis Gyroscope.

THERMNIGHT MAIN PARTS AND CONTROLS

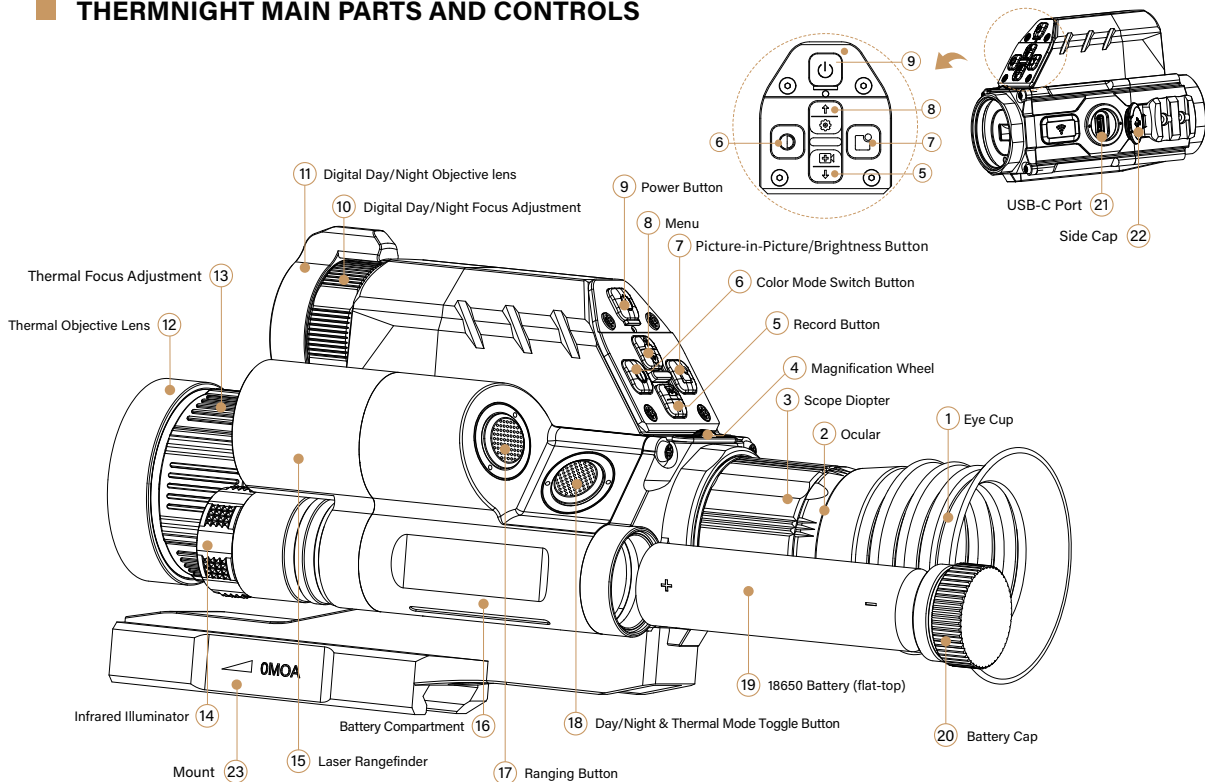

■ POWER SUPPLY

This device is powered by an external 18650 battery (flat-top) with up to 5 hours of operation time (when the IR Illuminator is turned off). TNC225R can be powered using a USB power supply. The USB-C port does not charge the 18650 battery.

Note: TNC225R cannot charge the 18650 battery.

Installing the 18650 Battery

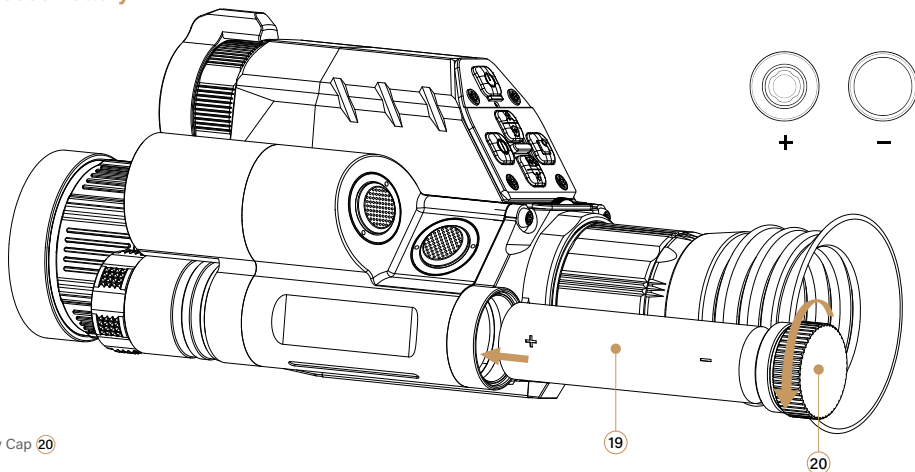

Unscrew the Battery Cap **20**

Insert 18650 battery **19** into battery compartment, positive side first

Screw the Battery Cap tight **20** till the end of thread

■ USB-C DATA TRANSFER

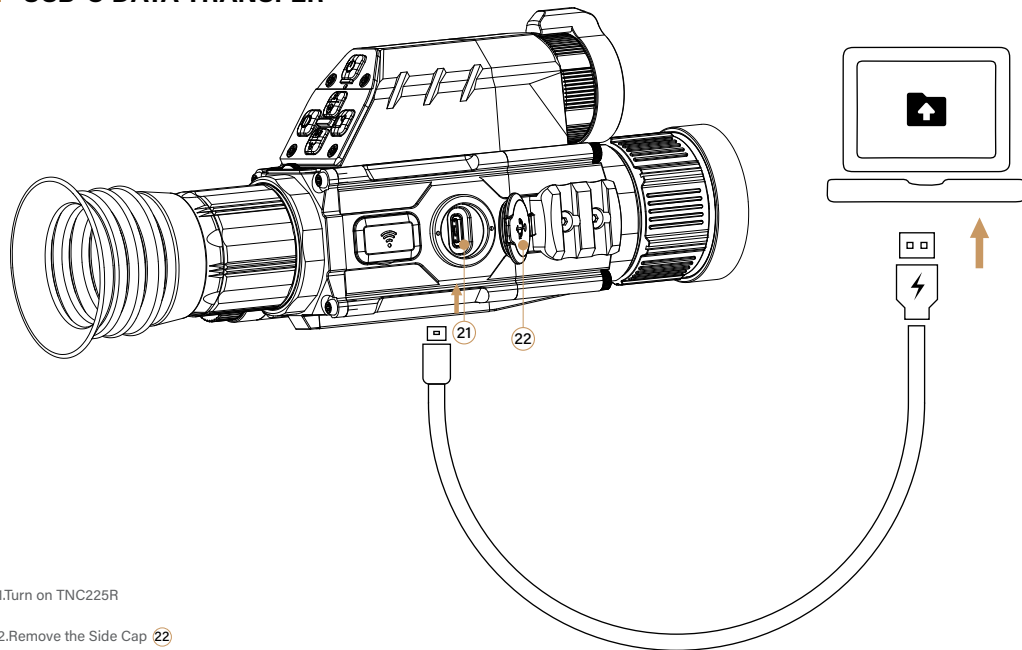

1. Turn on TNC225R

2. Remove the Side Cap ②

3. Plug USB-C cable into TNC225R USB-C port. ① The TNC225R will connect to your computer like a USB drive. Please copy recorded videos to your PC/ portable hard drive before browsing

Note: When connected with laptop/PC, find the DNT drive to check the video clips under its directory

REMOVABLE INFRARED ILLUMINATOR (IR TORCH)

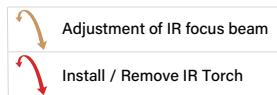
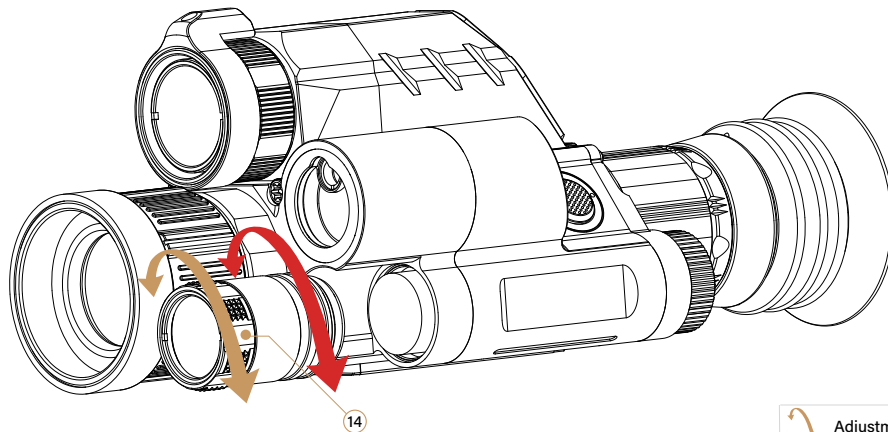

Rotate the IR Illuminator counter clockwise to remove from TNC225R body. Rotate clockwise to re-install IR Illuminator. IR head will move in and out to adjust beam size and intensity of focus.

Note: The scope is compatible with the 850nm or 940nm wavelength IR Illuminator **14**

CONTROL DESCRIPTION

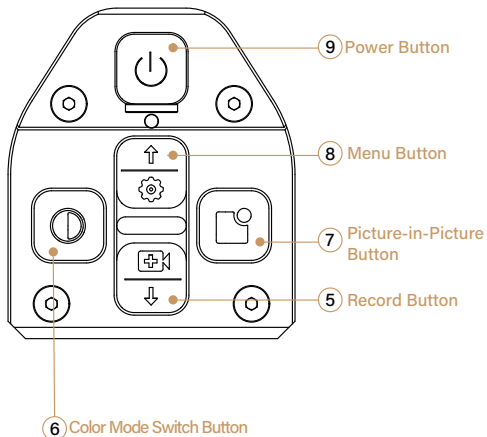

| Button | Status | Short press | Long press |
|--------|-------------------|---|-----------------------------------|
| ⏻ 9 | Off | -- | On |
| | On | Standby | Off |
| | Standby | Wake-up | -- |
| | Reticle Zeroing | Freeze/Continue | -- |
| ⚙️ 8 | On | Reticle Color Switch / Ranging Reticle Color Switch | Enter the Menu Interface |
| | Menu | Move cursor up | -- |
| | Reticle Zeroing | Single value reticle X/Y adjustment | Continuous reticle X/Y adjustment |
| 🎛️ 6 | Thermal mode | Switch Thermal Color Palettes | NUC (Non-Uniformity-Correction) |
| | Day Mode | -- | Black/White Mode |
| | Night Mode | IR Brightness Adjust | Color Mode |
| | Menu Interface | Back to the previous screen | -- |
| | Zeroing Interface | Move cursor to the left | Exit without saving |
| | Zeroing | Move cursor to the right | Save and Exit |
| 📺 7 | On | Screen Brightness Adjust | Picture-in-Picture On/Off |
| | Menu | Confirm | -- |
| | Zeroing | Move cursor to the right | Save and Exit |
| 📹 5 | On | Start RAV Recording (manual mode) | Start/End Recording |
| | Menu | Move cursor down | -- |
| | Reticle Zeroing | Single value reticle X/Y adjustment | Continuous reticle X/Y adjustment |

CONTROL DESCRIPTION

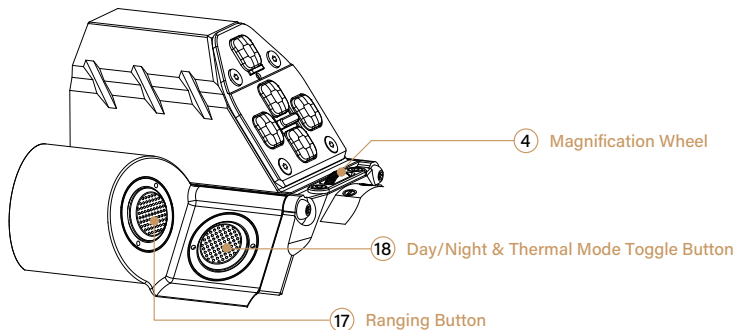

| Button | Status | Short press | Long press | Rotation |
|--------|---|--|------------------|--|
| 4 | On | -- | -- | Spin right to increase magnification and Spin left to decrease magnification |
| | Reticle Zeroing Interface | -- | -- | Spin right to increase magnification and Spin left to decrease magnification |
| 17 | Not connected to App | Show/Hide ranging icon and distances | Turn off ranging | -- |
| | Zeroing Interface Connection to APP Bluetooth | Ranging and Ballistic Calculation | Turn off ranging | -- |
| 18 | On | Switch between Day/Night Vision and Thermal mode | -- | -- |
| | Picture-In-Picture Mode Enabled | Switch between main and PIP display | -- | -- |

ON SCREEN DISPLAY

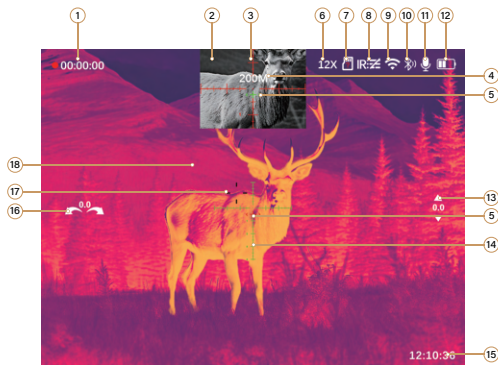

① Recording indicator: The recording timer indicates that the device is currently recording. The displayed number on the timer represents the duration of the current recording.

② Picture In Picture window (Night Vision or Thermal)

③ PIP reticle

④ Range distance display

⑤ PIP Ballistic Calculation Point of Aim

⑥ Current magnification (e.g. 12x)

⑦ Storage status (Only comes on when storage error occurs)

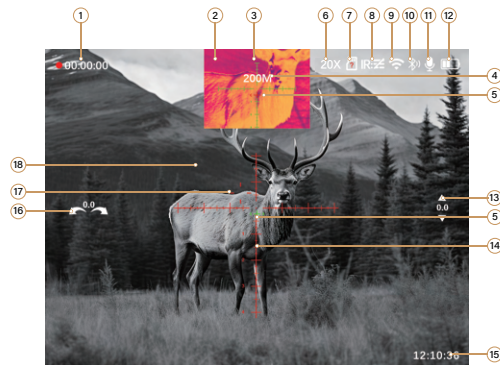

⑧ The IR icon indicates you are in Night Vision mode. The image will be black/white. The bars on the right indicate the IR Illuminator status and brightness.

| | |
|-----|---------------------------------------|
| IR: | Black and white mode; Illuminator off |
| IR: | Brightness Level 1 |
| IR: | Brightness Level 2 |
| IR: | Brightness Level 3 |
| IR: | Brightness Level 4 |
| IR: | Brightness Level 5 |

INTERFACE DESCRIPTION

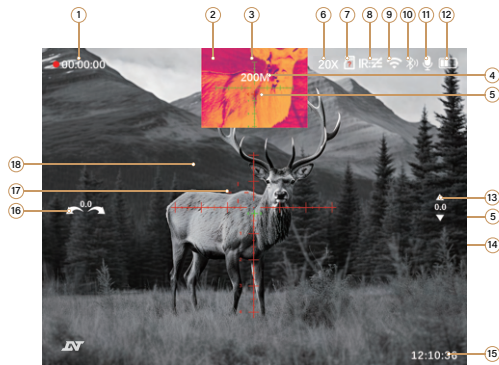
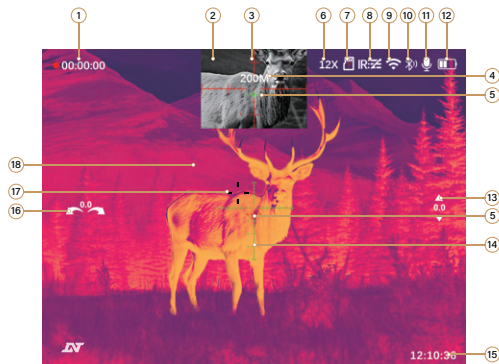

- ⑨ WiFi (WiFi on, WiFi off)
- ⑩ Bluetooth (Bluetooth on, Bluetooth off, Bluetooth connected)
- ⑪ Microphone, Indicates whether sounds to be included when recording
(Microphone on, Microphone off)
- ⑫ Battery status

| Icon | Status | Battery Status |
|------|-------------|-------------------------------|
| | 1 bar | 10% ~ 20% |
| | 2 bars | 20% ~ 50% |
| | 3 bars | 50% ~ 80% |
| | 4 bars | 80% ~ 100% |
| | USB Powered | connected to USB power supply |

- ⑬ Inclinometer
- ⑭ Reticle
- ⑮ Current time
- ⑯ Level indicator
- ⑰ Ranging reticle
- ⑱ Primary display in Digital Night Mode with Picture-In-Picture secondary display (5) in Thermal.

MENU LIST

Long press **Menu Button** ⑧ for 2 seconds to enter Menu List; There are 12 selections in total. Short press **Menu Button** ⑧ to move up, short press **Record Button** ⑤ to move down, short press **Color Mode Switch Button** ⑥ to go back and exit. Short press **PIP/brightness Button** ⑦ to enter and confirm selection.



(main screen)



Long Press 2s

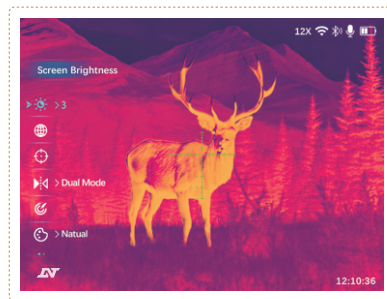

(menu)

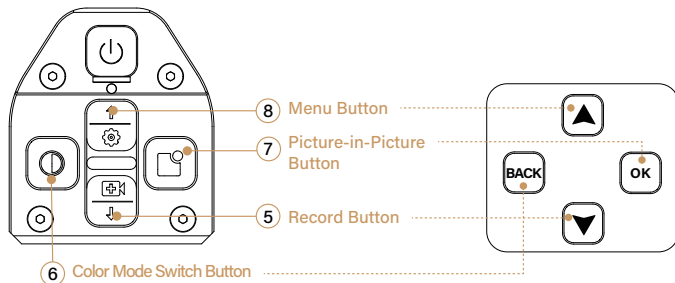

MENU LIST

Long press **Menu Button** ⑧ for 2 seconds to enter Menu List, and there are 12 selections as below chart.

| Icon | Description |
|------|---|
| | [Screen Brightness] Adjust screen brightness, levels 1-5 |
| | [Connections] WiFi and Bluetooth settings |
| | [Reticle Zeroing] Reticle zeroing |
| | [Digital/Thermal Switch] Select between Thermal mode, Digital Day/Night mode and Dual mode (PIP) |
| | [Ballistic Calculation] Real-Time or Ballistic Table Calculation Aiming Method Settings: Holdover or Dial-In |
| | [color Enhancement] Set digital Day/Night screen to natural or color enhanced image |
| | [Thermal Imaging Mode] Select between Natural, Enhanced and High Brightness |
| | [Thermal Imaging Image Configuration] Set thermal image color mode, Image Contrast, Image Brightness, Image Sharpness, Thermal Hotspot Tracking, and Dead Pixel Correction |
| | [Recoil Activated Recording] Set recoil activated recording function to auto or manual |
| | [Audio NO/OFF] Turn microphone ON/OFF for audio recording |
| | [Function Setting] Set Auto Power Off time, Loop recording time, position of the Picture-in-Picture Window, Gyroscope, and m/yds for range units |
| | [System Setting] Screen Shifting, Time Stamp ON/OFF, Date/Time, System languages, Format internal storage, Restore Default Setting, Available Storage and Current firmware Version |

MAIN FUNCTION DESCRIPTION

Zeroing The Reticle

Long press the **Menu Button** (8) for 2 seconds to enter Menu List, short press the **Record Button** (5) to move down to the **Reticle Setting Menu**  press the **Short press PIP Button** (7) to reticle setting menu



- Short press on **Power Button** (9) to freeze/unfreeze current image;
- Short press the **Picture-in-Picture Button** (7) to move the cursor to the right, short press the **Color Mode Switch Button** (6) to move the cursor to the left;
- Short press **Menu Button** (8) to increase current value by 1, long press (without release) to continuously increase the current value. Short press **Record Button** (5) to decrease the current value by 1, long press (without release) to continuously decrease the current value.
- Long Press **Color Mode Switch Button** (6) for 2 seconds to exit without saving, Reticle Zeroing; long press **Picture-in-Picture Button** (7) for 2 seconds to save and exit .

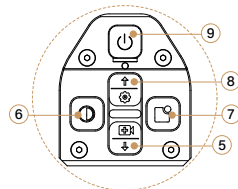

- ① 20x: the current objective magnification, adjustable with Magnification Wheel
- ② Thermal Imaging: indicates the reticle zeroing of the thermal channel is currently in progress, thermal channel/digital channel available
- ③ A: Current Ballistic profiles, up to 5 (A-E) profiles for reticle setting
- ④ X=0: current horizontal position of reticle
- ⑤ Y=0: current vertical position of reticle
- ⑥ Color: green, red, yellow, black
- ⑦ Style: MILReticle, Open Dot Crosshair, Duplex, German open T, + Small Cross

Digital Day/Night Vision Zeroing (Example)

- Step 1: Aim at target at preferred zeroing distance. Adjust the **Objective lens** ⑫ so target is in focus. Align reticle on target. Shoot one round at target, the bullet will impact on or near the target. For example, point of impact (T) as shown in Figure (1).
- Step 2: Keep your TNC225R steady and reticle aimed at your original point of aim, short press the **Power Button** ⑨ . This will freeze the current image making it easier to zero the reticle.
- Step 3: Use the **PIP/Brightness Button** ⑦ to move over and highlight X. Press **Menu Button** ⑥ to move reticle to the right. Press **Record Button** ⑤ to move reticle to the left. Move reticle to point of impact if it is in the FOV of the frozen image.
- Step 4: Press **PIP/Brightness Button** ⑦ to move and highlight Y. Pressing **Menu Button** ⑧ will move reticle up. Pressing **Record Button** ⑤ will move reticle down. Move reticle to point of impact.
- Step 5: Long press **Color Mode Switch Button** ⑥ to exit without saving. Long press **PIP/Brightness Button** ⑦ to save and exit.

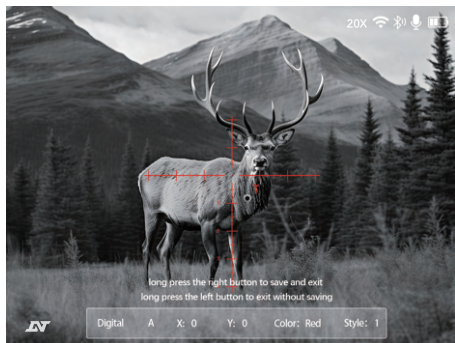

Figure (1)



Figure (2)

Thermal Zeroing (Example)

- Step 1: Aim at target at preferred zeroing distance. Adjust the **Thermal Objective lens** ⑫ so target is in focus. Align reticle on target. Fire one round at target, the bullet will impact on or near the target. For example, point of impact (T) as shown in Figure (1).
- Step 2: Keep your TNC225R steady and reticle aimed at your point of aim, short press the **Power Button** ⑨. This will freeze the current image making it easier to zero the reticle.
- Step 3: Use **PIP/Brightness Button** ⑦ to move over and highlight X. Press **Menu Button** ⑧ to move reticle to the right. Press **Record Button** ⑤ to move reticle to the left. Move reticle to point of impact if it is in the FOV of the frozen image.
- Step 4: Press **PIP/Brightness Button** ⑦ to move and highlight Y. Pressing **Menu Button** ⑧ will move reticle up. Pressing **Record Button** ⑤ will move reticle down. Move reticle to point of impact.
- Step 5: Long press **Color Mode Switch Button** ⑥ to exit without saving. Long press **PIP/Brightness Button** ⑦ to save and exit.

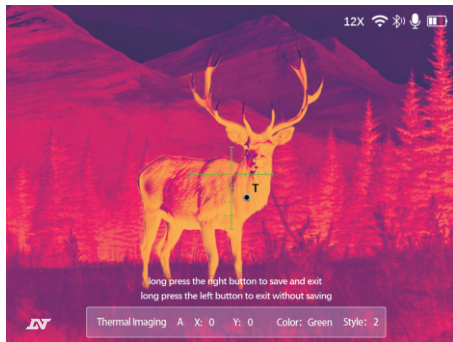

Figure (1)

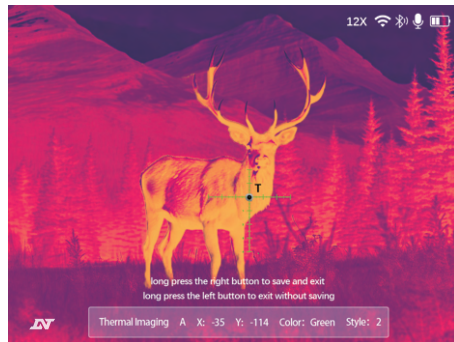

Figure (2)

Dual Mode Reticle Zeroing (Example)

Turn on the Picture-in-Picture function:

Step 1: Aim at target at preferred zeroing distance. Adjust the **Objective lens** (12) so target is in focus. Align reticle on target. Shoot one round at target, the bullet will impact on or near the target. For example, point of impact (T) as shown in Figure (1).

Step 2: Keep your TNC225R steady and reticle aimed at your original point of aim, short press the **Power Button** (9). This will freeze the current image making it easier to zero the reticle.

Step 3: Use the **PIP/Brightness Button** (7) to move over and highlight X. Press **Menu Button** (8) to move reticle to the right. Press **Record Button** (5) to move reticle to the left. Move reticle to point of impact if it is in the FOV of the frozen image.

Step 4: Press **PIP/Brightness Button** (7) to move and highlight Y. Pressing **Menu button** (8) will move reticle up. Pressing **Record Button** (5) will move reticle down. Move reticle to point of impact.

Step 5: Long press **Color Mode Switch Button** (6) to exit without saving. Long press **PIP/Brightness Button** (7) to save and exit.

Note: Once digital Day/Night and Thermal are both zeroed at your preferred distance. Engaging a target closer or further than your zero distance may cause Point of Aim to be different from each other. This is to compensate ballistics and scope height over bore.

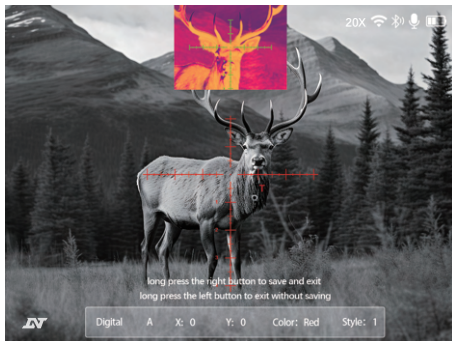

Figure (1)

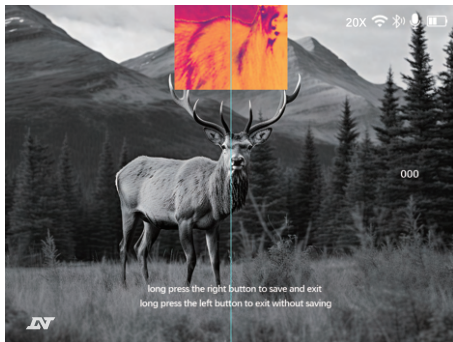

Figure (2)

Screen Shifting

Long press **Menu Button** ⑧ for 2 seconds to enter the menu, move the cursor to "System Setting"->"Screen Shifting", short press **Picture-in-Picture Button** ⑦ to enter the image drift interface:

- Short press **Color Mode Switch Button** ⑥ or **Picture-in-Picture Button** ⑦ to move the digital Day/Night screen, when the digital target and thermal target are the same, long press for 2 seconds after **Picture-in-Picture Button** ⑦ to save the current setting.



(Before image drift)



(After image drift)

Picture-in-Picture Function

Default size of the secondary PIP window is 10% of the main screen. You can position the PIP window in the upper left, center, or upper right of the main screen. To change PIP position, enter the Menu: **Function Setting - Position of small window in Picture-in-Picture - Left / Center / Right.**



(Left)

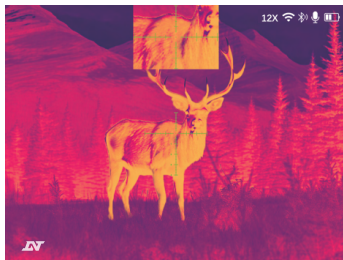

(Center)



(Right)

Picture-in-Picture Function

- **Dual Mode**

While in Dual Mode, short press of the **Day/Night & Thermal Mode Toggle Button** (18) will toggle the displays for the main screen and PIP window. See Figure (1), Main screen shows thermal channel while the PIP window is displaying digital night vision. Pressing the **Day/Night & Thermal Mode Toggle Button** (18) will flip the displays Figure (2) so the main screen shows the digital night mode and the PIP window shows the thermal channel.

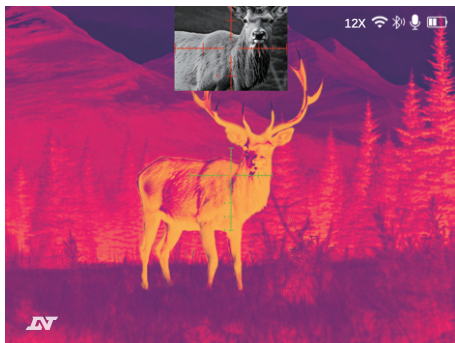

Figure (1)



Figure (2)

Picture-in-Picture Function

- **Day/ Night Vision Mode & Thermal Mode**

In this mode, the PIP window magnification defaults to 2 times that of the large window.

Note: In this mode, short press the Day/Night & Thermal Toggle Button (18), you can switch from Figure (1) to Figure (2).

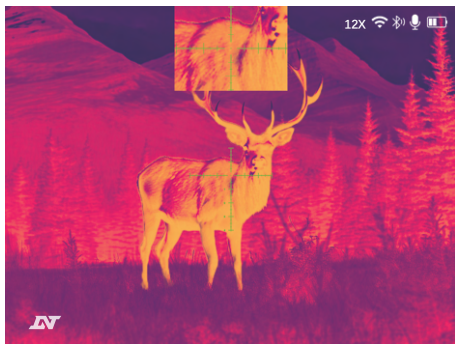

Figure (1)



Figure (2)

Range Finding

The LRF will only measure the distance, if you have the Ballistics Calculation set to OFF.

- Short press the **Ranging Button** to turn on the distance measuring function. The Ranging Icon (17) will appear and display current range distance. (4)
(It will automatically and continuously measure the distance until you press the ranging button again to turn the LRF off.)
- another short press or long press the **Ranging Button** for 1.5 seconds to turn off the distance measurement function. The Ranging Icon (17) and distance range reading will disappear from the screen.



(First short press Ranging Button)



(Long press Ranging Button for 1.5 seconds)

Ballistic Calculation-Real Time Calculation

- Enter the menu, select "Ballistic Calculation" - "Ballistic Calculation" - "Real Time Calculation".
- Range your target by pressing the **Range Button** on the TNC225R. The App will calculate the ballistic drop for the distance provided by the LRF and send the information back to the TNC225R. If you have Hold Over set, there will be a small box showing you where to aim. If you chose Dial-In for your Aiming Method, the reticle will shift position for your new aiming point.

Ballistic Calculation - Ballistic Table

- Enter the menu, press Ballistic Calculation and select "Ballistic Table" make sure the Bluetooth is on and connected to the device (when there is a Ballistic Table on the device you don't need to turn on the Bluetooth to acquire profile from the APP).
- Click Send icon  to update the APP Ballistic Table to the device. After the profile is sent, the TNC225R will calculate the ballistics without needing to be connected to the App.

Note: Ballistic Calculation only works if you create a ballistic profile based on your rifle and ammunition.

| Distance (M) | MRAD | MCA | MRAD | MCA | Speed (M/S) |
|--------------|------|-------|------|------|-------------|
| 0 | 0.0 | 0.00 | 0.0 | 0.00 | 1185.0 |
| 10 | 3.1 | 10.52 | 0.0 | 0.01 | 1177.1 |
| 20 | 1.2 | 4.19 | 0.0 | 0.01 | 1169.3 |
| 30 | 0.6 | 2.17 | 0.0 | 0.01 | 1161.5 |
| 40 | 0.3 | 1.20 | 0.0 | 0.02 | 1153.8 |
| 50 | 0.2 | 0.66 | 0.0 | 0.02 | 1146.9 |
| 60 | 0.1 | 0.35 | 0.0 | 0.03 | 1139.1 |
| 70 | 0.0 | 0.17 | 0.0 | 0.03 | 1130.2 |
| 80 | 0.0 | 0.07 | 0.0 | 0.03 | 1122.6 |
| 90 | 0.0 | 0.01 | 0.0 | 0.04 | 1114.9 |
| 100 | 0.0 | 0.00 | 0.0 | 0.04 | 1107.2 |
| 110 | 0.0 | 0.01 | 0.0 | 0.04 | 1099.5 |
| 120 | 0.0 | 0.05 | 0.0 | 0.05 | 1091.8 |
| 130 | 0.0 | 0.10 | 0.0 | 0.05 | 1084.1 |
| 140 | 0.0 | 0.16 | 0.0 | 0.05 | 1076.4 |
| 150 | 0.1 | 0.24 | 0.0 | 0.06 | 1068.9 |
| 160 | 0.1 | 0.32 | 0.0 | 0.06 | 1061.1 |
| 170 | 0.1 | 0.41 | 0.0 | 0.06 | 1053.5 |
| 180 | 0.1 | 0.51 | 0.0 | 0.07 | 1045.9 |

(Ballistic Table interface)

| Distance (M) | MRAD | RCX | CM |
|--------------|------|-----|-----|
| 1 | N/A | N/A | N/A |
| 2 | N/A | N/A | N/A |
| 3 | N/A | N/A | N/A |
| 4 | N/A | N/A | N/A |
| 5 | N/A | N/A | N/A |
| 6 | N/A | N/A | N/A |
| 7 | N/A | N/A | N/A |
| 8 | N/A | N/A | N/A |
| 9 | N/A | N/A | N/A |
| 10 | N/A | N/A | N/A |
| 11 | N/A | N/A | N/A |

(Customized Ballistic Table interface)

Aiming Method-Holdover

Enter the menu, select "**Ballistic Calculation**" - "Aiming Method" - "Holdover".

- First short press the **Ranging Button** to activate the ranging function, the Ranging Icon (17) and distance (4) will display on the screen.
 - Aim the Ranging Icon at your target. The distance will be displayed at the top of the screen. Press the **Ranging Button** again to accept the distance, the Ballistic Calculator will create an aiming solution.
 - The Ranging Icon (17) will be replaced with the **newly calculated point of aim**. Align the **newly calculated point of aim** with your target.
- Long press the **Ranging Button** for 1.5 seconds to turn off the Laser Range Finder.

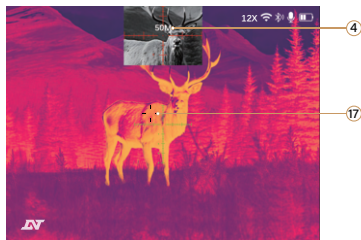

(First short press Ranging Button)



(Second short press Ranging Button)

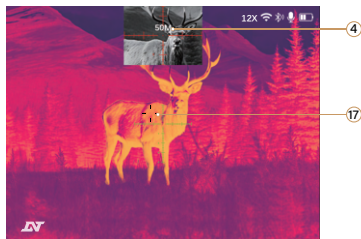

(Third short press Ranging Button)

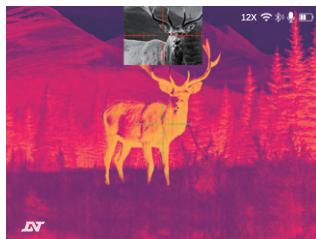

(Long press Ranging Button for 1.5 seconds)

Aiming Method-Dial in

Enter the menu, select "**Ballistic Calculation**" - "Aiming Method" - "Dial in".

- Short press the **Ranging Button** to activate the ranging function, the Ranging Icon (17) and distance reading (4) will display on the screen.
 - Aim the Ranging Icon at your target and the distance will be displayed at the top of the screen. Press the **Ranging Button** again to accept the distance and the reticle will move to your **newly calculated point of aim**. Use this new reticle position as your new point of aim for your target at distance.
- Long press the **Ranging Button** to turn off the Laser Range Finder. The reticle will return to your zeroed position.

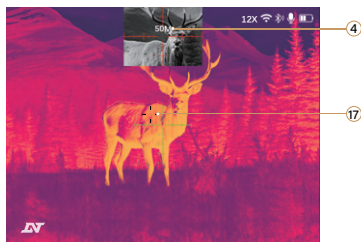

(First short press Ranging Button)

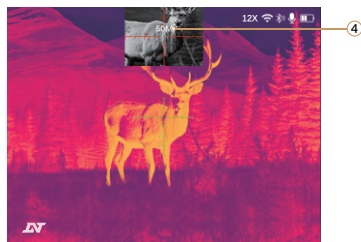

(Second short press Ranging Button)



(Third short press Ranging Button)

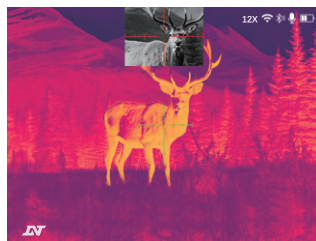

(Long press Ranging Button for 1.5 seconds)

Ballistic Calculation in Dual Mode

Ballistic Calculation in Dual Mode ensures that both thermal and digital points are the same as long as they are zeroed at the same target distance.

- Zero Digital Night Vision and Thermal at a distance of 30 meters, as shown in Figure (1).
- Aim at your target, as shown in Figure (2).
- Perform Ballistic Calculation and confirm the point of aim for Digital Night Vision and Thermal are the same, as shown in figure (3).



Figure (1)

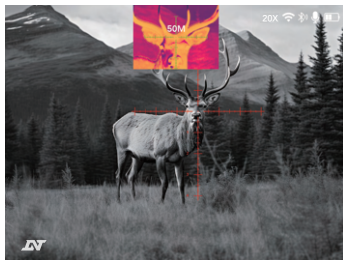

Figure (2)

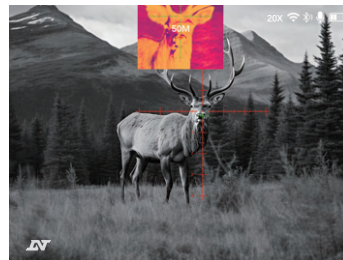

Figure (3)

■ FCC WARNING

This device complies with part 15 of the FCC Rules. Operation is subject to the following two conditions: (1) this device may not cause harmful interference, and (2) this device must accept any interference received, including interference that may cause undesired operation.

Any changes or modifications not expressly approved by the party responsible for compliance could void the user's authority to operate the equipment.

NOTE: This equipment has been tested and found to comply with the limits for a Class B digital device, pursuant to Part 15 of the FCC Rules. These limits are designed to provide reasonable protection against harmful interference in a residential installation. This equipment generates, uses and can radiate radio frequency energy and, if not installed and used in accordance with the instructions, may cause harmful interference to radio communications. However, there is no guarantee that interference will not occur in a particular installation.

If this equipment does cause harmful interference to radio or television reception, which can be determined by turning the equipment off and on, the user is encouraged to try to correct the interference by one or more of the following measures:

- Reorient or relocate the receiving antenna.
- Increase the separation between the equipment and receiver.
- Connect the equipment into an outlet on a circuit different from that to which the receiver is connected.
- Consult the dealer or an experienced radio/TV technician for help. The device has been evaluated to meet general RF exposure requirement. The device can be used in portable exposure condition without restriction.



www.dntoptics.com